

RIGEL - 31W

LLIG2 Lay-In-Grid Cleanroom Luminaire (595 x 595mm)

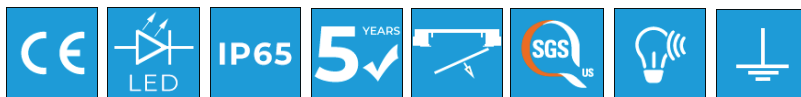

Overview

A recessed ceiling grid mounted LED luminaire for installation in cleanroom grid ceilings. The fitting is IP65 rated and front/bottom accessed. The removable front access panel allows bottom access for maintenance, while maintaining the cleanroom integrity. The luminaire is available in DALI dimmable.

Installation

The fitting is inserted into the ceiling grid in the cleanroom ceiling and laid into position. The removable front plate allows access to the components from the cleanroom side.



Rigel Lay-in



Electrical Data:

Voltage (V)	220-240
Frequency (Hz)	50
Power (W)	31
Power Factor	0.95
Total Power (W)	37

Dimensions:

Length (mm)	595
Width (mm)	595
Height (mm)	45
Ope Dimension (mm)	N/A
Weight (kg)	6.5

Lighting Data:

LED Type	Everlight
Luminous Flux	3600lm
CCT	4000K
CRI	>80
Efficacy	120lm/cw
Life Expectancy	>70,000hrs
Macadam Step	3
Driver	Tridonic Advanced Series

Body / Diffuser:

Body Material	Sheet Steel
Body Finish	Powder coated Epoxy Paint
Body Colour	RAL 9010
Diffuser	3mm TP (a) Polycarbonate
Cable Tail Lead	3m PVC/PVC

Technical Data:

IP Rating	IP65
Max T (a)	35
Walk-on Loading	N/A
Temp Range	-20°C to + 40°C
Gland position	Top/Rear

Options:

DALI Dimmable	Yes, on request
Emergency	Yes, Integrated 4W LED strip
Self/Auto Test (Emer.)	Yes, on request
Diffuser Option	Toughened Glass option
Cable Tail Lead options	Yes, on request
Gland Position Options	Side entry options
Low UV / Amber	Yes, inc dual option

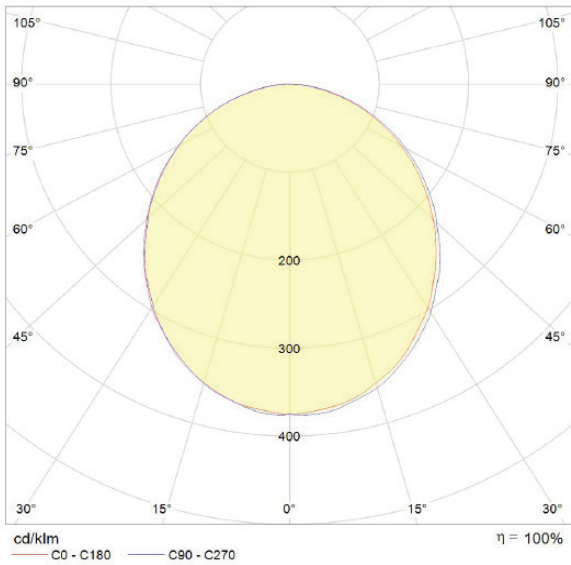

LED Light Plate

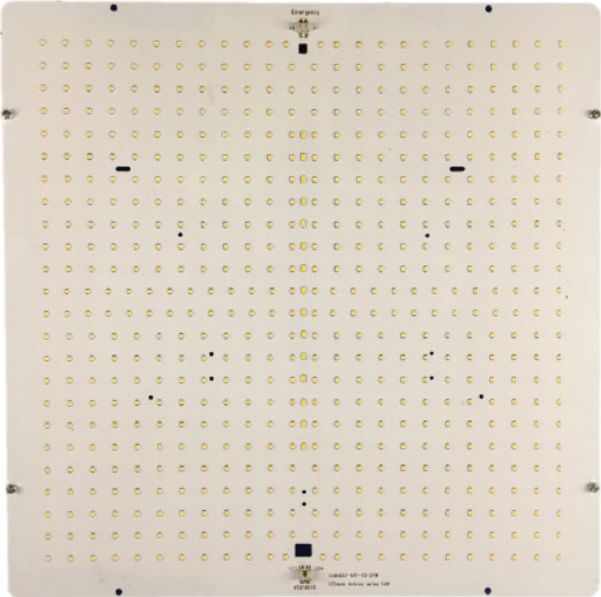

To Specify:

Recessed, IP65, Lay-in Grid LED Cleanroom Luminaire with steel body, SMD LEDs, Tridonic Driver and chemical resistant polycarbonate diffuser, suitable for installation in controlled environment grid ceilings. The luminaire is 'Bottom Access' only and suitable for the highest grades of cleanroom.

Drawings

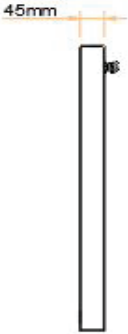

SIDE VIEW

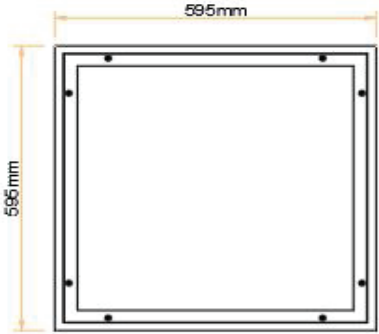

BOTTOM PLAN VIEW

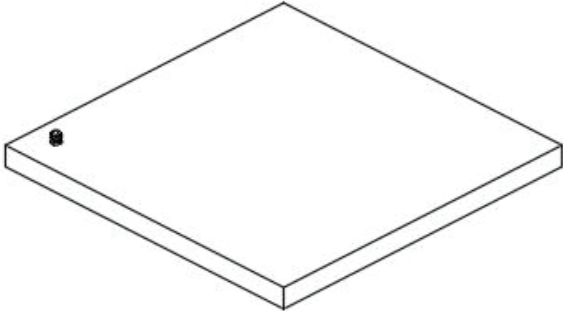

TOP VIEW ISOMETRIC

RIGEL - 42W

LLIG2 Lay-In-Grid Cleanroom Luminaire (595 x 595mm)



Overview

A recessed ceiling grid mounted LED luminaire for installation in cleanroom grid ceilings. The fitting is IP65 rated and front/bottom accessed. The removable front access panel allows bottom access for maintenance, while maintaining the cleanroom integrity. The luminaire is available in DALI dimmable.

Installation

The fitting is inserted into the ceiling grid in the cleanroom ceiling and laid into position. The removable front plate allows access to the components from the cleanroom side.



Rigel Lay-in



Electrical Data:

Voltage (V)	220-240
Frequency (Hz)	50
Power (W)	42
Power Factor	0.95
Total Power (W)	47

Dimensions:

Length (mm)	595
Width (mm)	595
Height (mm)	45
Ope Dimension (mm)	N/A
Weight (kg)	6.5

Lighting Data:

LED Type	Everlight
Luminous Flux	5040lm
CCT	4000K
CRI	>80
Efficacy	120lm/cw
Life Expectancy	>70,000hrs
Macadam Step	3
Driver	Tridonic Advanced Series

Body / Diffuser:

Body Material	Sheet Steel
Body Finish	Powder coated Epoxy Paint
Body Colour	RAL 9010
Diffuser	3mm TP (a) Polycarbonate
Cable Tail Lead	3m PVC/PVC

Technical Data:

IP Rating	IP65
Max T (a)	35
Walk-on Loading	N/A
Temp Range	-20°C to + 40°C
Gland position	Top/Rear

Options:

DALI Dimmable	Yes, on request
Emergency	Yes, Integrated 4W LED strip
Self/Auto Test (Emer.)	Yes, on request
Diffuser Option	Toughened Glass option
Cable Tail Lead options	Yes, on request
Gland Position Options	Side entry options
Low UV / Amber	Yes, inc dual option
Smart Lighting options	Yes, on request

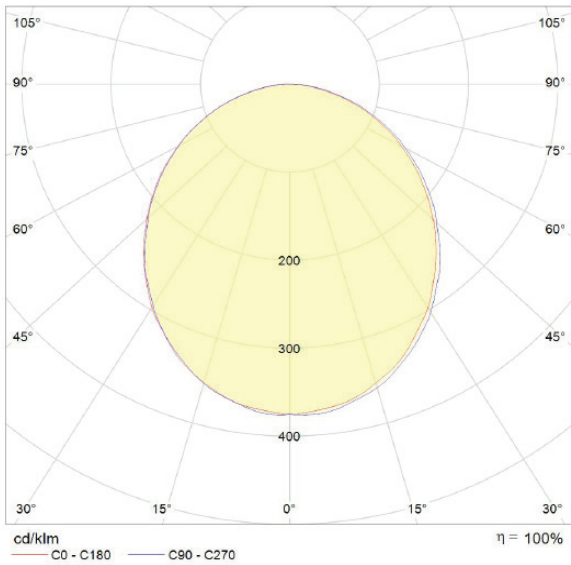

LED Light Plate

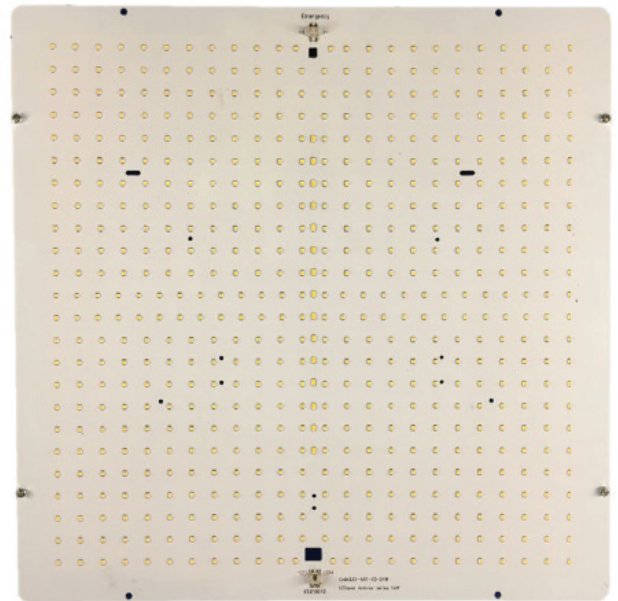

To Specify:

Recessed, IP65, Lay-in Grid LED Cleanroom Luminaire with steel body, SMD LEDs, Tridonic Driver and chemical resistant polycarbonate diffuser, suitable for installation in controlled environment grid ceilings. The luminaire is 'Bottom Access' only and suitable for the highest grades of cleanroom.

Drawings



SIDE VIEW

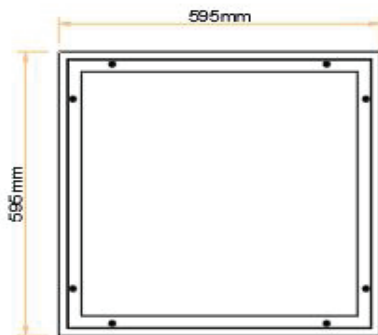

BOTTOM PLAN VIEW

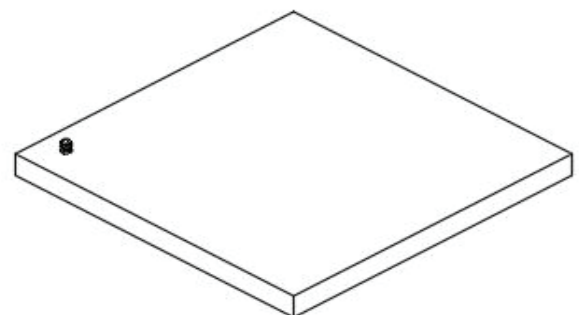

TOP VIEW ISOMETRIC

RIGEL - 54W

LLIG2 Lay-In-Grid Cleanroom Luminaire (595 x 595mm)



Overview

A recessed ceiling grid mounted LED luminaire for installation in cleanroom grid ceilings. The fitting is IP65 rated and front/bottom accessed. The removable front access panel allows bottom access for maintenance, while maintaining the cleanroom integrity. The luminaire is available in DALI dimmable.

Installation

The fitting is inserted into the ceiling grid in the cleanroom ceiling and laid into position. The removable front plate allows access to the components from the cleanroom side.



Rigel Lay-in



Electrical Data:	
Voltage (V)	220-240
Frequency (Hz)	50
Power (W)	54
Power Factor	0.95
Total Power (W)	58

Dimensions:	
Length (mm)	595
Width (mm)	595
Height (mm)	45
Ope Dimension (mm)	N/A
Weight (kg)	6.5

Lighting Data:	
LED Type	Everlight
Luminous Flux	6480lm
CCT	4000K
CRI	>80
Efficacy	120lm/cw
Life Expectancy	>70,000hrs
Macadam Step	3
Driver	Tridonic Advanced Series

Body / Diffuser:	
Body Material	Sheet Steel
Body Finish	Powder coated Epoxy Paint
Body Colour	RAL 9010
Diffuser	3mm TP (a) Polycarbonate
Cable Tail Lead	3m PVC/PVC

Technical Data:	
IP Rating	IP65
Max T (a)	35
Walk-on Loading	N/A
Temp Range	-20°C to + 40°C
Gland position	Top/Rear

Options:	
DALI Dimmable	Yes, on request
Emergency	Yes, Integrated 4W LED strip
Self/Auto Test (Emer.)	Yes, on request
Diffuser Option	Toughened Glass option
Cable Tail Lead options	Yes, on request
Gland Position Options	Side entry options
Low UV / Amber	Yes, inc dual option
Smart Lighting options	Yes, on request

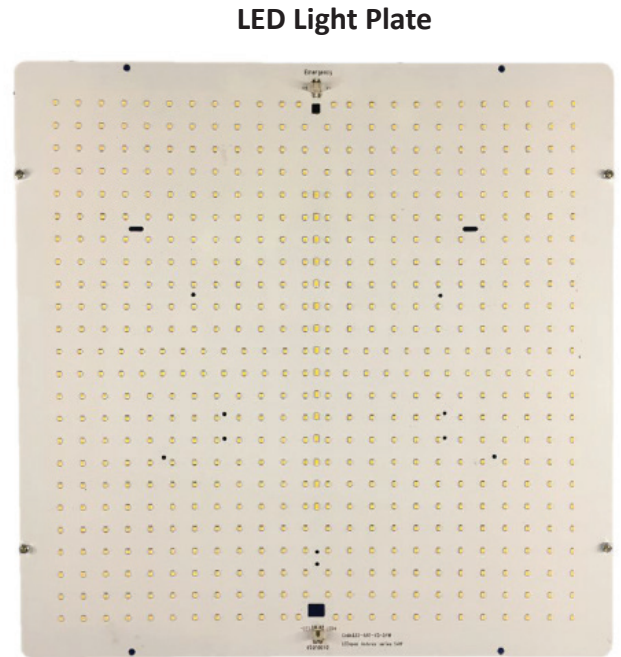
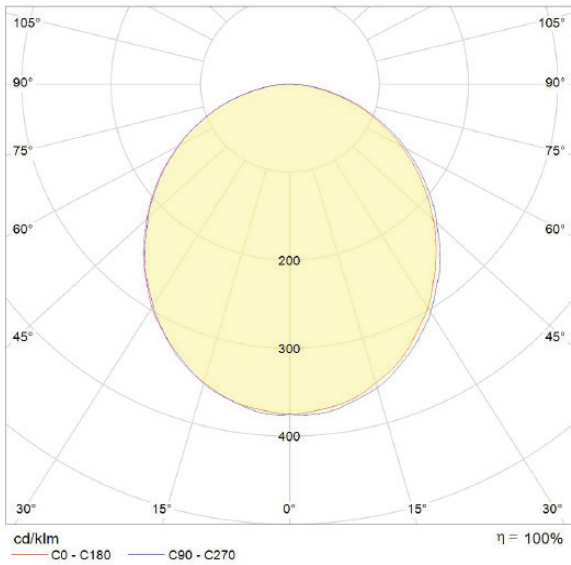

To Specify:

Recessed, IP65, Lay-in Grid LED Cleanroom Luminaire with steel body, SMD LEDs, Tridonic Driver and chemical resistant polycarbonate diffuser, suitable for installation in controlled environment grid ceilings. The luminaire is 'Bottom Access' only and suitable for the highest grades of cleanroom.

Drawings



SIDE VIEW

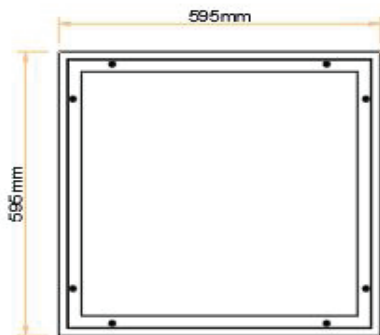

BOTTOM PLAN VIEW

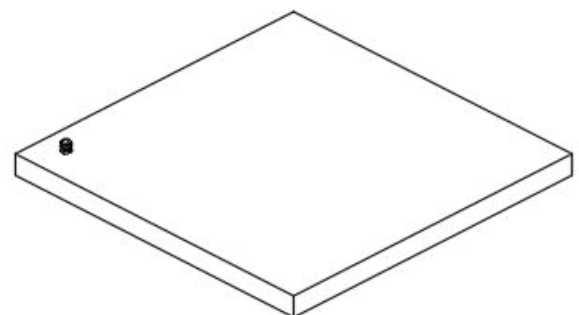

TOP VIEW ISOMETRIC

RIGEL - 70W

LLIG2 Lay-In-Grid Cleanroom Luminaire (595 x 595mm)



Overview

A recessed ceiling grid mounted LED luminaire for installation in cleanroom grid ceilings. The fitting is IP65 rated and front/bottom accessed. The removable front access panel allows bottom access for maintenance, while maintaining the cleanroom integrity. The luminaire is available in DALI dimmable.

Installation

The fitting is inserted into the ceiling grid in the cleanroom ceiling and laid into position. The removable front plate allows access to the components from the cleanroom side.



Rigel Lay-in



Electrical Data:

Voltage (V)	220-240
Frequency (Hz)	50
Power (W)	70
Power Factor	0.95
Total Power (W)	76

Dimensions:

Length (mm)	595
Width (mm)	595
Height (mm)	45
Ope Dimension (mm)	N/A
Weight (kg)	6.5

Lighting Data:

LED Type	Everlight
Luminous Flux	8400lm
CCT	4000K
CRI	>80
Efficacy	120lm/cw
Life Expectancy	>70,000hrs
Macadam Step	3
Driver	Tridonic Advanced Series

Body / Diffuser:

Body Material	Sheet Steel
Body Finish	Powder coated Epoxy Paint
Body Colour	RAL 9010
Diffuser	3mm TP (a) Polycarbonate
Cable Tail Lead	3m PVC/PVC

Technical Data:

IP Rating	IP65
Max T (a)	35
Walk-on Loading	N/A
Temp Range	-20°C to + 40°C
Gland position	Top/Rear

Options:

DALI Dimmable	Yes, on request
Emergency	Yes, Integrated 4W LED strip
Self/Auto Test (Emer.)	Yes, on request
Diffuser Option	Toughened Glass option
Cable Tail Lead options	Yes, on request
Gland Position Options	Side entry options
Low UV / Amber	Yes, inc dual option
Smart Lighting options	Yes, on request

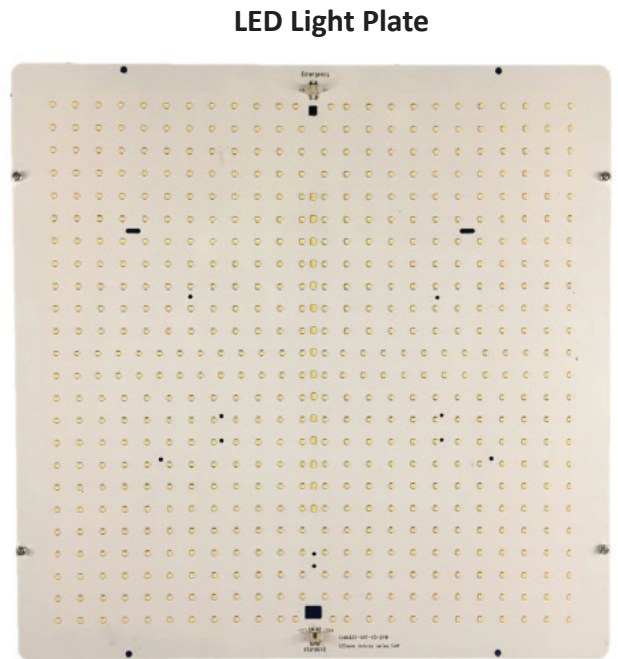
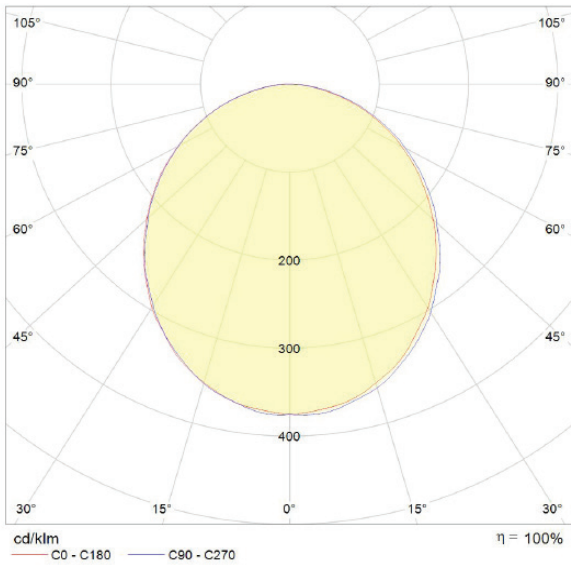

To Specify:

Recessed, IP65, Lay-in Grid LED Cleanroom Luminaire with steel body, SMD LEDs, Tridonic Driver and chemical resistant polycarbonate diffuser, suitable for installation in controlled environment grid ceilings. The luminaire is 'Bottom Access' only and suitable for the highest grades of cleanroom.

Drawings



SIDE VIEW

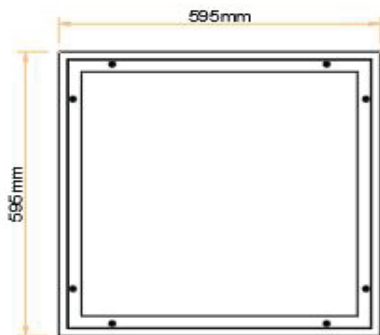

BOTTOM PLAN VIEW

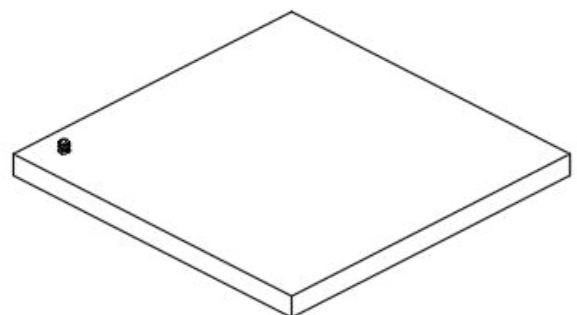

TOP VIEW ISOMETRIC

RIGEL - 31w

LLIG2 Lay-In-Grid Cleanroom Luminaire (610 x 610mm)

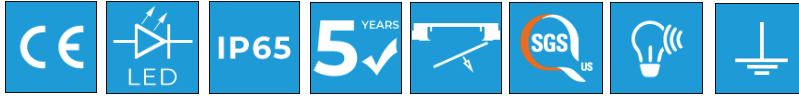

Overview

A recessed ceiling grid mounted LED luminaire for installation in cleanroom grid ceilings. The fitting is IP65 rated and front/bottom accessed. The removable front access panel allows bottom access for maintenance, while maintaining the cleanroom integrity. The luminaire is available in DALI dimmable.

Installation

The fitting is inserted into the ceiling grid in the cleanroom ceiling and laid into position. The removable front plate allows access to the components from the cleanroom side.



Rigel Lay-in

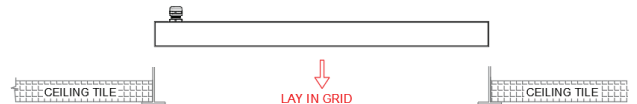

Electrical Data:	
Voltage (V)	220-240
Frequency (Hz)	50
Power (W)	31
Power Factor	0.95
Total Power (W)	37

Dimensions:	
Length (mm)	610
Width (mm)	610
Height (mm)	45
Ope Dimension (mm)	N/A
Weight (kg)	6.6

Lighting Data:	
LED Type	Everlight
Luminous Flux	3600lm
CCT	4000K
CRI	>80
Efficacy	120lm/cw
Life Expectancy	>70,000hrs
Macadam Step	3
Driver	Tridonic Advanced Series

Body / Diffuser:	
Body Material	Sheet Steel
Body Finish	Powder coated Epoxy Paint
Body Colour	RAL 9010
Diffuser	3mm TP (a) Polycarbonate
Cable Tail Lead	3m PVC/PVC

Technical Data:	
IP Rating	IP65
Max T (a)	35
Walk-on Loading	N/A
Temp Range	-20°C to + 40°C
Gland position	Top/Rear

Options:	
DALI Dimmable	Yes, on request
Emergency	Yes, Integrated 4W LED strip
Self/Auto Test (Emer.)	Yes, on request
Diffuser Option	Toughened Glass option
Cable Tail Lead options	Yes, on request
Gland Position Options	Side entry options
Low UV / Amber	Yes, inc dual option
Smart Lighting options	Yes, on request

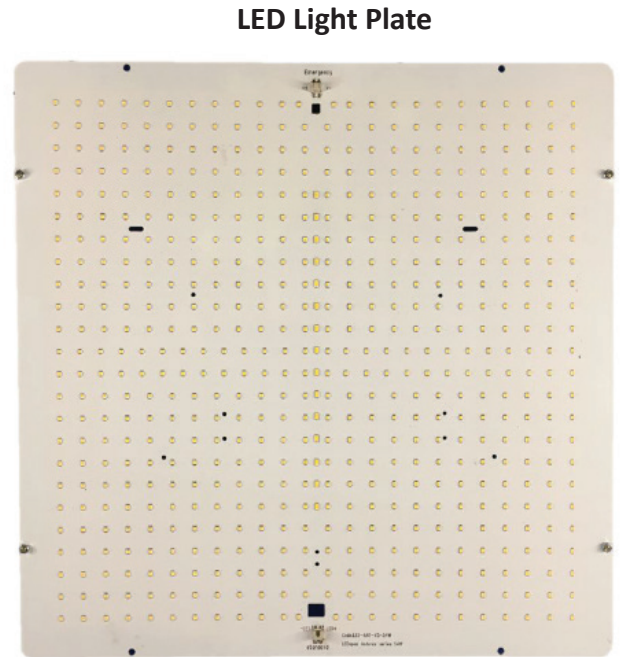
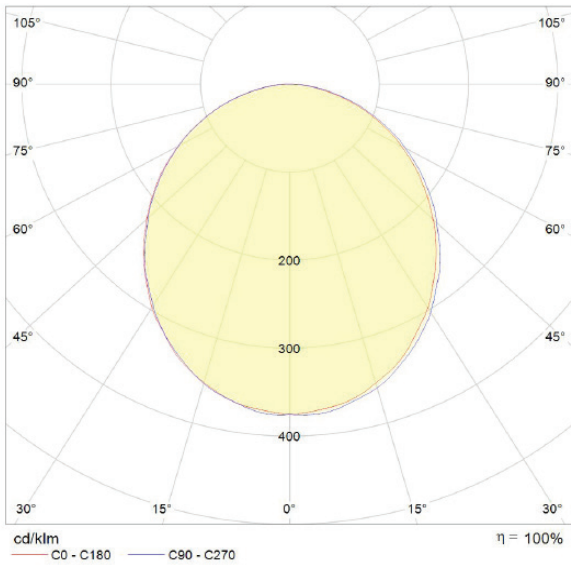

To Specify:

Recessed, IP65, Lay-in Grid LED Cleanroom Luminaire with steel body, SMD LEDs, Tridonic Driver and chemical resistant polycarbonate diffuser, suitable for installation in controlled environment grid ceilings. The luminaire is 'Bottom Access' only and suitable for the highest grades of cleanroom.

Drawings

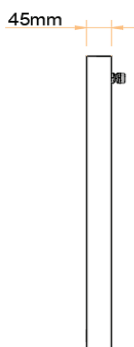

SIDE VIEW

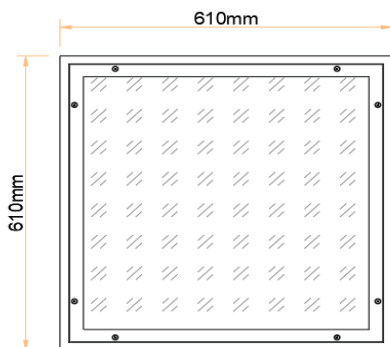

BOTTOM PLAN VIEW

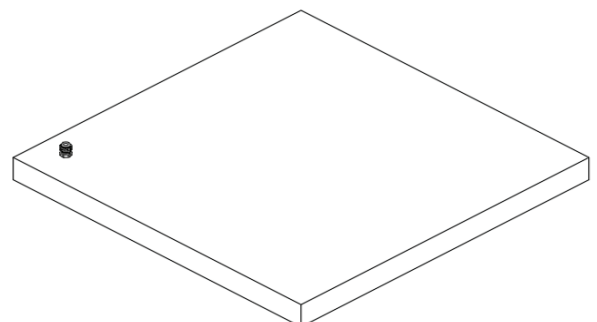

TOP VIEW ISOMETRIC

RIGEL - 42w

LLIG2 Lay-In-Grid Cleanroom Luminaire (610 x 610mm)

CLEANROOM.net

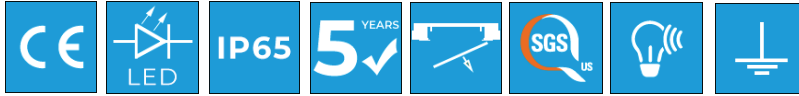

Overview

A recessed ceiling grid mounted LED luminaire for installation in cleanroom grid ceilings. The fitting is IP65 rated and front/bottom accessed. The removable front access panel allows bottom access for maintenance, while maintaining the cleanroom integrity. The luminaire is available in DALI dimmable.

Installation

The fitting is inserted into the ceiling grid in the cleanroom ceiling and laid into position. The removable front plate allows access to the components from the cleanroom side.



Rigel Lay-in

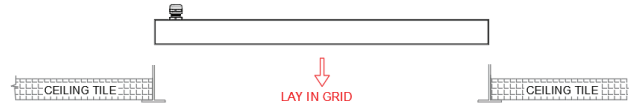

Electrical Data:	
Voltage (V)	220-240
Frequency (Hz)	50
Power (W)	42
Power Factor	0.95
Total Power (W)	47

Dimensions:	
Length (mm)	610
Width (mm)	610
Height (mm)	45
Ope Dimension (mm)	N/A
Weight (kg)	6.6

Lighting Data:	
LED Type	Everlight
Luminous Flux	5040lm
CCT	4000K
CRI	>80
Efficacy	120lm/cw
Life Expectancy	>70,000hrs
Macadam Step	3
Driver	Tridonic Advanced Series

Body / Diffuser:	
Body Material	Sheet Steel
Body Finish	Powder coated Epoxy Paint
Body Colour	RAL 9010
Diffuser	3mm TP (a) Polycarbonate
Cable Tail Lead	3m PVC/PVC

Technical Data:	
IP Rating	IP65
Max T (a)	35
Walk-on Loading	N/A
Temp Range	-20°C to + 40°C
Gland position	Top/Rear

Options:	
DALI Dimmable	Yes, on request
Emergency	Yes, Integrated 4W LED strip
Self/Auto Test (Emer.)	Yes, on request
Diffuser Option	Toughened Glass option
Cable Tail Lead options	Yes, on request
Gland Position Options	Side entry options
Low UV / Amber	Yes, inc dual option
Smart Lighting options	Yes, on request

www.cleanroom.net info@cleanroom.net
Ireland & International Tel: +353 (0) 56 449 1491, UK Tel: +44 (0) 161 464 8744

The future of Controlled Environment Lighting just got brighter

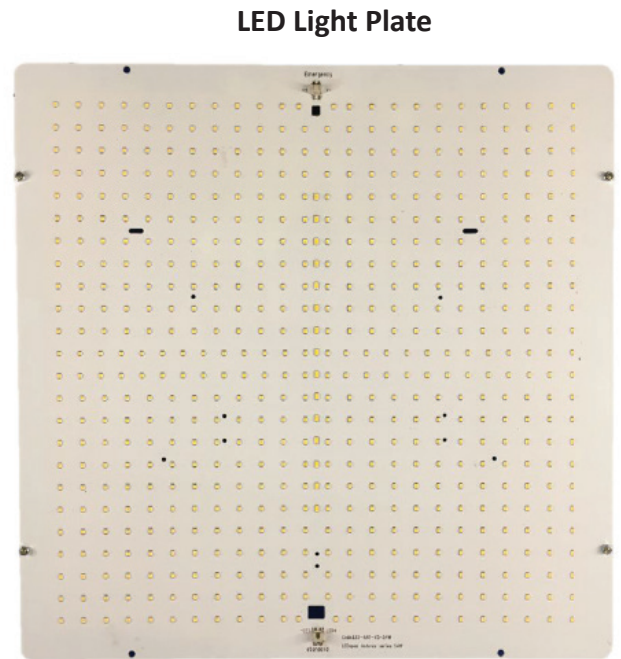
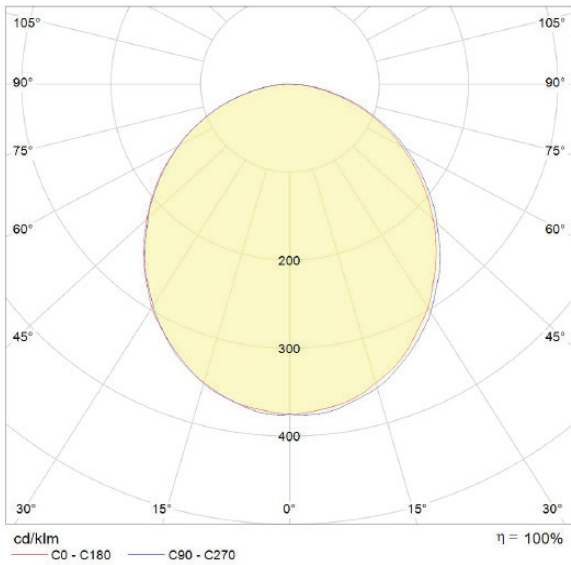

To Specify:

Recessed, IP65, Lay-in Grid LED Cleanroom Luminaire with steel body, SMD LEDs, Tridonic Driver and chemical resistant polycarbonate diffuser, suitable for installation in controlled environment grid ceilings. The luminaire is 'Bottom Access' only and suitable for the highest grades of cleanroom.

Drawings

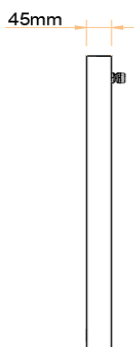

SIDE VIEW

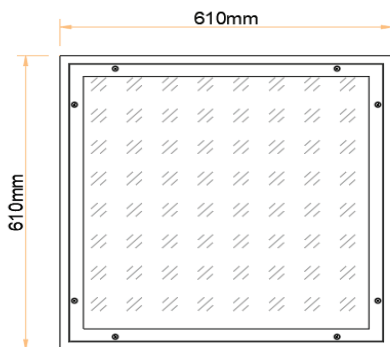

BOTTOM PLAN VIEW

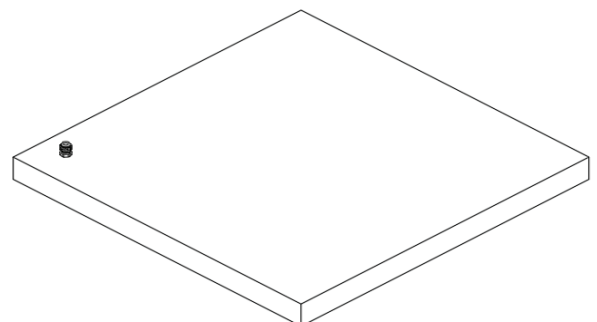

TOP VIEW ISOMETRIC

RIGEL - 54w

LLIG2 Lay-In-Grid Cleanroom Luminaire (610 x 610mm)

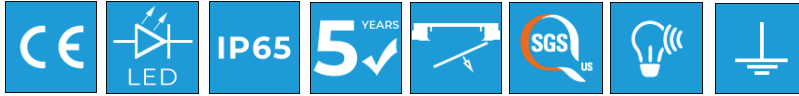

Overview

A recessed ceiling grid mounted LED luminaire for installation in cleanroom grid ceilings. The fitting is IP65 rated and front/bottom accessed. The removable front access panel allows bottom access for maintenance, while maintaining the cleanroom integrity. The luminaire is available in DALI dimmable.

Installation

The fitting is inserted into the ceiling grid in the cleanroom ceiling and laid into position. The removable front plate allows access to the components from the cleanroom side.



Rigel Lay-in

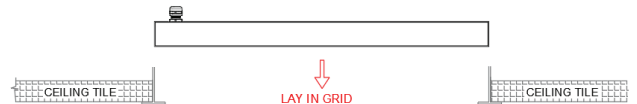

Electrical Data:	
Voltage (V)	220-240
Frequency (Hz)	50
Power (W)	54
Power Factor	0.95
Total Power (W)	58

Dimensions:	
Length (mm)	610
Width (mm)	610
Height (mm)	45
Ope Dimension (mm)	N/A
Weight (kg)	6.6

Lighting Data:	
LED Type	Everlight
Luminous Flux	6480lm
CCT	4000K
CRI	>80
Efficacy	120lm/cw
Life Expectancy	>70,000hrs
Macadam Step	3
Driver	Tridonic Advanced Series

Body / Diffuser:	
Body Material	Sheet Steel
Body Finish	Powder coated Epoxy Paint
Body Colour	RAL 9010
Diffuser	3mm TP (a) Polycarbonate
Cable Tail Lead	3m PVC/PVC

Technical Data:	
IP Rating	IP65
Max T (a)	35
Walk-on Loading	N/A
Temp Range	-20°C to + 40°C
Gland position	Top/Rear

Options:	
DALI Dimmable	Yes, on request
Emergency	Yes, Integrated 4W LED strip
Self/Auto Test (Emer.)	Yes, on request
Diffuser Option	Toughened Glass option
Cable Tail Lead options	Yes, on request
Gland Position Options	Side entry options
Low UV / Amber	Yes, inc dual option
Smart Lighting options	Yes, on request

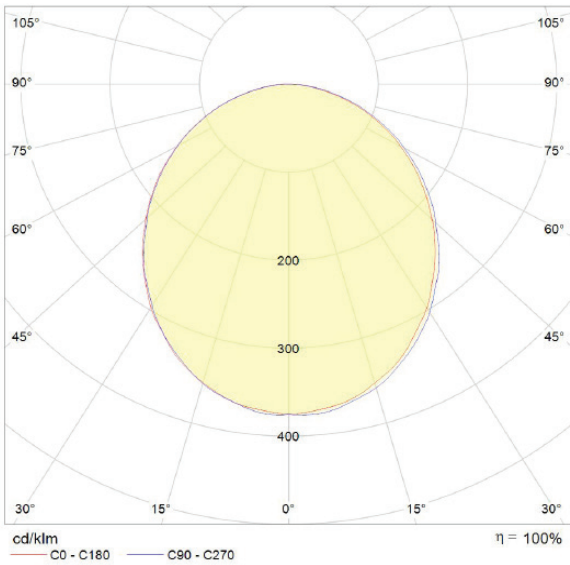

LED Light Plate

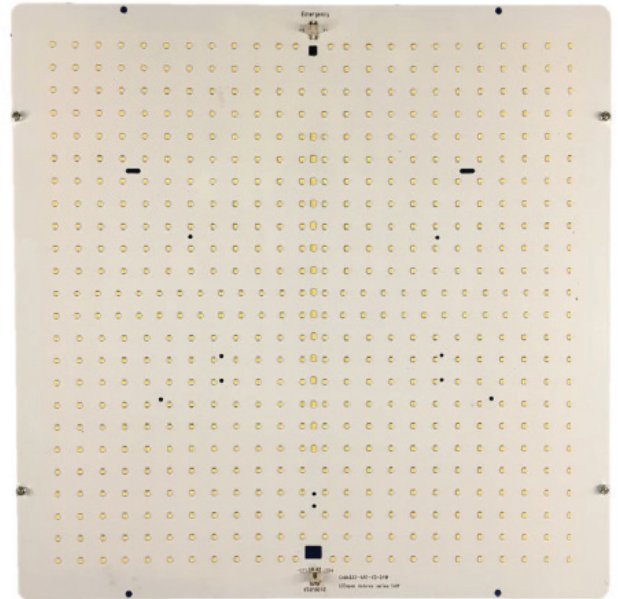

To Specify:

Recessed, IP65, Lay-in Grid LED Cleanroom Luminaire with steel body, SMD LEDs, Tridonic Driver and chemical resistant polycarbonate diffuser, suitable for installation in controlled environment grid ceilings. The luminaire is 'Bottom Access' only and suitable for the highest grades of cleanroom.

Drawings

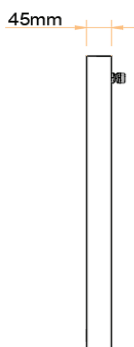

SIDE VIEW

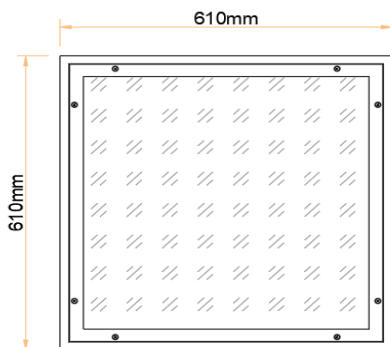

BOTTOM PLAN VIEW

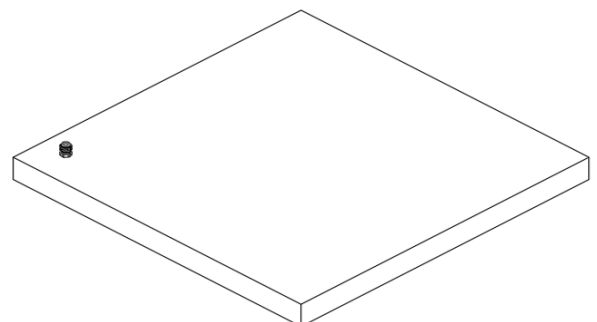

TOP VIEW ISOMETRIC

RIGEL - 70W

LLIG2 Lay-In-Grid Cleanroom Luminaire (610 x 610mm)



Overview

A recessed ceiling grid mounted LED luminaire for installation in cleanroom grid ceilings. The fitting is IP65 rated and front/bottom accessed. The removable front access panel allows bottom access for maintenance, while maintaining the cleanroom integrity. The luminaire is available in DALI dimmable.

Installation

The fitting is inserted into the ceiling grid in the cleanroom ceiling and laid into position. The removable front plate allows access to the components from the cleanroom side.



Rigel Lay-in



Electrical Data:

Voltage (V)	220-240
Frequency (Hz)	50
Power (W)	70
Power Factor	0.95
Total Power (W)	76

Dimensions:

Length (mm)	610
Width (mm)	610
Height (mm)	45
Ope Dimension (mm)	N/A
Weight (kg)	6.6

Lighting Data:

LED Type	Everlight
Luminous Flux	8400lm
CCT	4000K
CRI	>80
Efficacy	120lm/cw
Life Expectancy	>70,000hrs
Macadam Step	3
Driver	Tridonic Advanced Series

Body / Diffuser:

Body Material	Sheet Steel
Body Finish	Powder coated Epoxy Paint
Body Colour	RAL 9010
Diffuser	3mm TP (a) Polycarbonate
Cable Tail Lead	3m PVC/PVC

Technical Data:

IP Rating	IP65
Max T (a)	35
Walk-on Loading	N/A
Temp Range	-20°C to + 40°C
Gland position	Top/Rear

Options:

DALI Dimmable	Yes, on request
Emergency	Yes, Integrated 4W LED strip
Self/Auto Test (Emer.)	Yes, on request
Diffuser Option	Toughened Glass option
Cable Tail Lead options	Yes, on request
Gland Position Options	Side entry options
Low UV / Amber	Yes, inc dual option
Smart Lighting options	Yes, on request

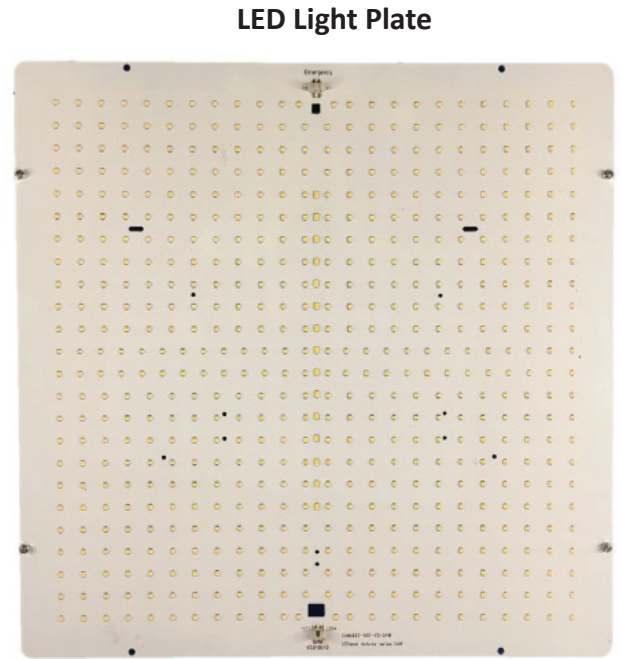
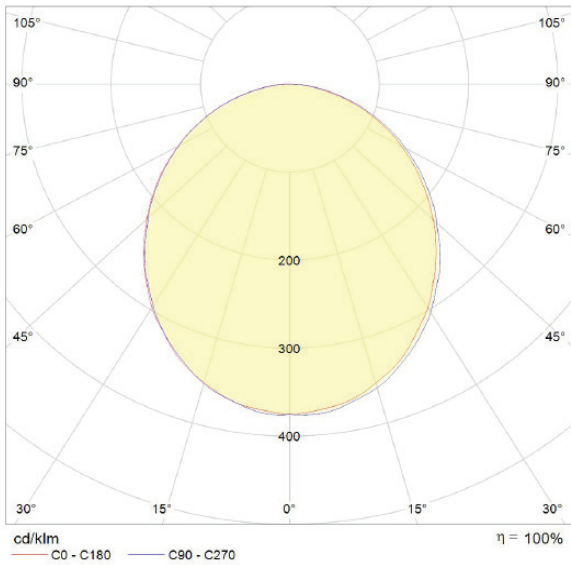

To Specify:

Recessed, IP65, Lay-in Grid LED Cleanroom Luminaire with steel body, SMD LEDs, Tridonic Driver and chemical resistant polycarbonate diffuser, suitable for installation in controlled environment grid ceilings. The luminaire is 'Bottom Access' only and suitable for the highest grades of cleanroom.

Drawings

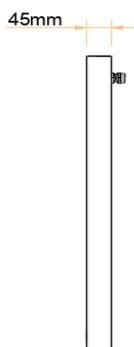

SIDE VIEW

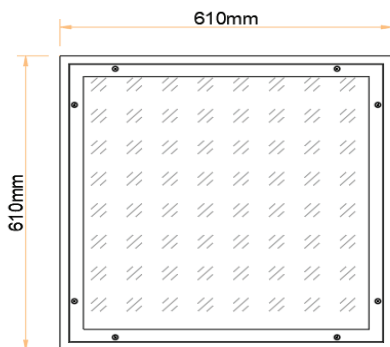

BOTTOM PLAN VIEW

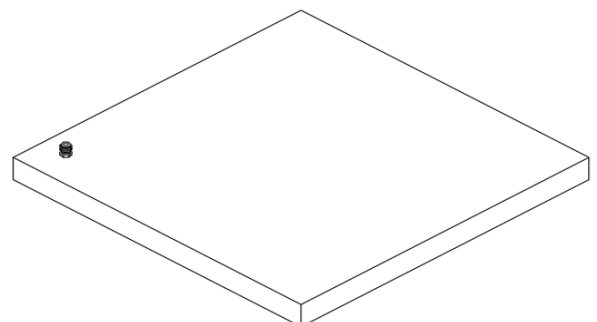

TOP VIEW ISOMETRIC